

ADAPTABLE SPEED REDUCERS



PREMIUM ADAPTABLE SPEED REDUCERS

Premium Adaptable Speed Reducers are available in a range of six sizes from size 112 to 337 (28.6 to 85.7 mm centres) and meets the requirement of all drives upto 7.5 kw. A range of standard ratios gives a wide choice of output speeds.

The number of mounting arrangements of adaptable units is almost unlimited, giving the widest possible field of application. The same basic case is used for each size and can be mounted using detachable feet or, where desired, can be located without feet. The drawing of dimensions gives case details together with sizes for Nos. 1, 2 and 3 feet.

Alternative basic shaft handing arrangements are available, R and L. These references should always be quoted, together with feet details.

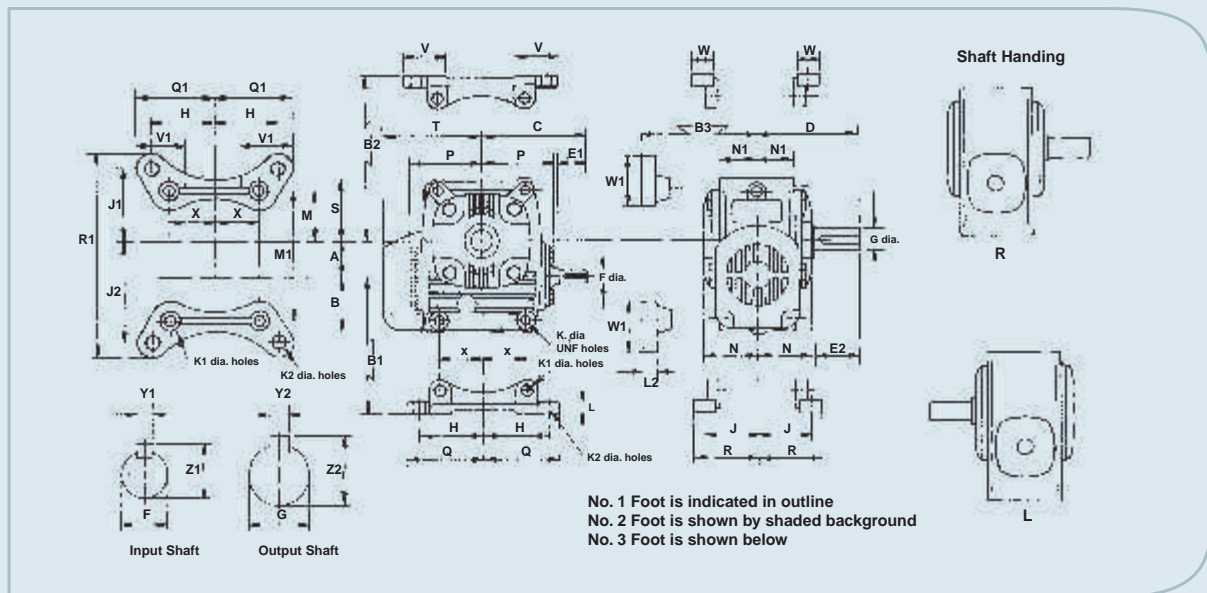

Principal Dimensions (mm)

SIZE	A	B	C	D	E1	E2	E3	E4	F	G	K	M
112	28.6	44.5	90	79	29	35	25.4	32	11.113 11.102	15.875 15.865	6.4	41.3
162	41.3	50.8	110	98	41	48	38	44	15.875 15.865	19.050 19.037	6.4	47.6
200	50.8	58.7	133	117	48	57	44	54	5.875 15.865	25.400 25.387	7.9	60.3
237	60.3	68.3	159	140	57	70	54	67	19.050 19.037	28.575 28.562	9.5	71.4
287	73.0	77.8	191	168	70	83	67	79	22.225 22.212	31.750 31.735	11.1	88.9
337	85.7	90.6	219	200	83	98	79	95	25.400 25.387	38.100 38.085	12.7	100.0

SIZE	M1	N	N1	P	S	T	X	Y1	Y2	Z1	Z2
112	104.8	41	30	62	51	81	34.9	3.226 3.175	4.826 4.775	12.50 12.29	17.98 17.78
162	130.2	49	37	71	57	89	39.7	4.826 4.775	4.826 4.775	17.98 17.78	21.16 20.96
200	158.8	59	43	86	71	111	50.8	4.826 4.775	6.408 6.350	17.98 17.78	28.19 27.99
237	187.3	68	51	98	84	130	60.3	4.826 4.775	7.976 7.925	21.16 20.96	32.05 31.85
287	225.4	81	64	119	103	154	76.2	6.401 6.350	7.976 7.925	25.02 24.82	35.23 35.03
337	260.4	98	76	133	116	175	85.7	6.401 6.350	9.576 9.525	28.19 27.99	42.27 42.06

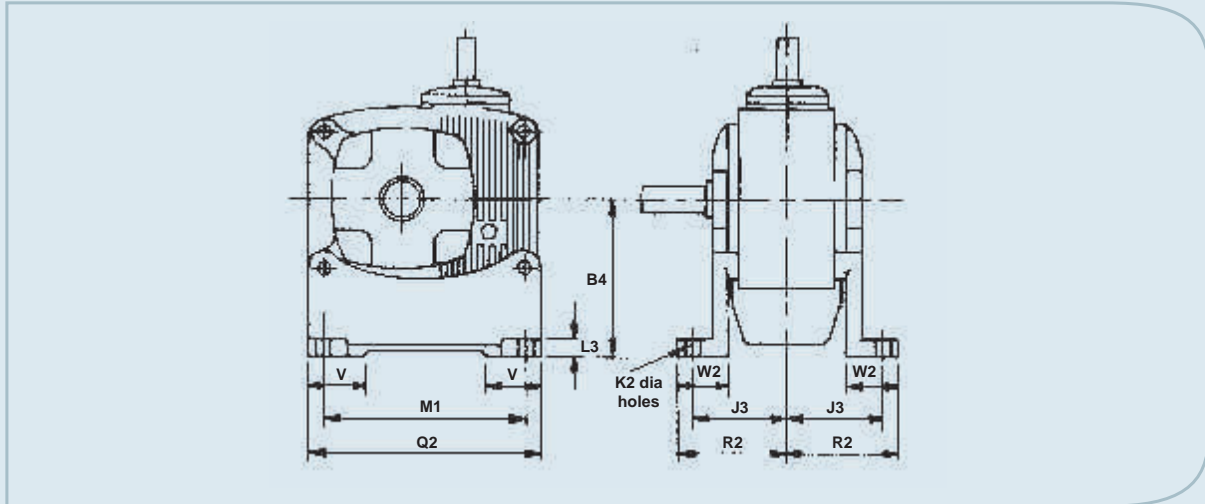

No. 1 Foot

SIZE	B1	B2	H	J	K1	K2	L	N1	Q	R	V	W	X
112	52.4	58.7	52.4	41.3	7.1	8.7	13	30	62	51	35	19	34.9
162	60.3	66.7	58.7	49.2	7.1	10.3	14	37	70	60	38	22	39.7
200	69.9	82.6	76.2	57.2	8.7	10.3	14	43	91	73	49	29	50.8
237	84.1	100.0	87.3	68.3	10.3	11.9	17	51	103	84	54	32	60.3
287	95.3	120.7	106.4	82.6	11.9	13.5	21	64	124	100	60	35	76.2
337	109.5	134.9	119.1	96.8	13.5	15.1	22	76	138	116	67	38	85.7

No. 2 Foot

B3	H	J1	J2	K1	K2	L	M	M1	Q1	R1	V1	W1	X
54.0	52.4	57.2	79.4	7.1	8.7	13	41.3	104.8	64	159	37	41	34.9
63.5	58.7	65.1	100.0	7.1	10.3	14	47.6	130.2	71	191	40	46	39.7
69.9	76.2	82.6	120.7	8.7	10.3	14	60.3	158.8	89	229	51	52	50.8
82.6	87.3	95.3	139.7	10.3	11.9	17	71.4	187.3	103	267	57	59	60.3
98.4	106.4	114.3	161.9	11.9	13.5	21	88.9	225.4	124	311	65	65	76.2
114.3	119.1	128.6	188.9	13.5	15.1	22	100.0	260.4	138	356	73	73	85.7

No. 3 Foot

SIZE	B4	J3	L	M1	O2	R2	V	W2
112	93.7	55.6	10	104.8	124	65	35	29
162	101.6	65.1	11	130.2	152	76	38	32
200	127.0	71.4	14	158.8	191	89	49	38
237	146.1	84.1	17	187.3	219	100	54	41
287	173.0	101.6	19	225.4	260	119	60	48
337	193.7	115.9	21	260.4	298	133	67	49

As improvements in design are continually being made, this specification is not to be regarded as binding in detail, and dimensions are subject to alteration without notice.

Lubrication

The diagrams illustrate typical arrangements of mounting and gives details of the respective positions of Breather, Oil Level and Drain Plugs. Normally units are despatched with plugs fitted as shown in the first diagram, which shows the basic "space" mounting. Where units are required to operate in other positions, it is necessary to reposition the Breather Plug as indicated. The Breather Plug should always be kept clean and free from blockage.

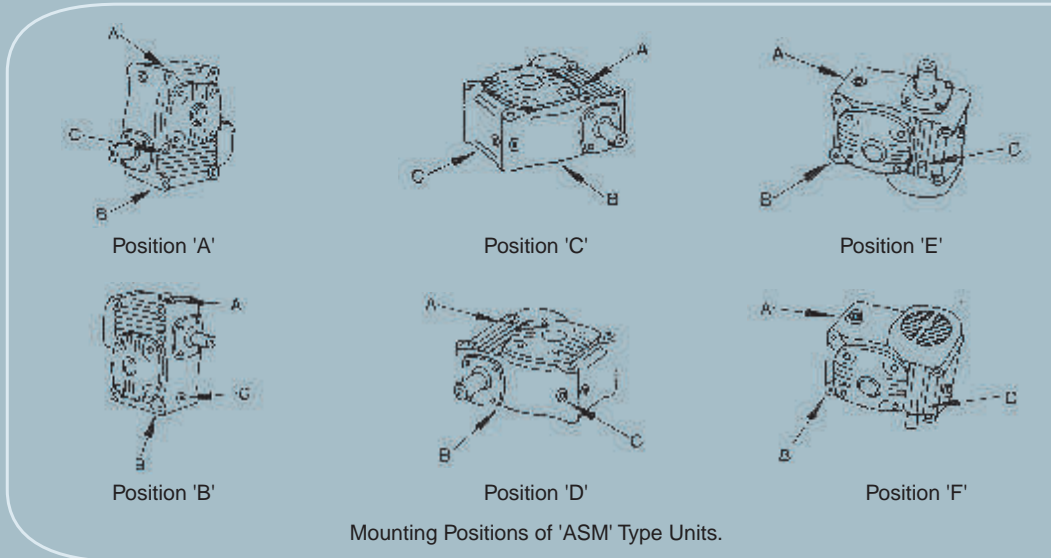

Recommended Lubricant
GREAVES TRAXOL - G32



PREMIUM

Premium Energy Transmission Limited

Head Office : P. B. No. 5, Chinchwad, Pune - 411 019, India.

Tel. : (91-20) 27475141 / 42 / 43 / 44, Fax : (91-20) 27450287, 27476601.

Website : www.premiumtransmission.com

Manufacturing Units :

- **Unit-I :** Chinchwad, Pune. Tel. : (91-20) 27475141 / 42 / 43 / 44, Fax : (91-20) 27450287, 27476601.
- **Unit-II :** West Bengal. Tel.: (91-3174) 222231 / 32 / 33 / 37, Fax : (91-3174) 222234.
- **Unit-III :** Chlkalthana, Aurangabad. Tel.: (91-240) 2485521, 2485856, 2485056, Fax : (91-240) 2485756.
- **Unit-IV :** Chlkalthana, Aurangabad. Tel.: (91-240) 2482858, 2471298, Fax : (91-240) 2482857.

Regional Offices :

- **Mumbai :** Tel.: (91-22) 24223747, 24365510, Fax : (91-22) 24367785, 24379555.
- **New Delhi :** Tel. : (91-11) 23730554 (8 Lines), Fax : (91-11) 23359782 / 23357739.
- **Kolkata :** Tel.: (91-33) 22424316, 22423780, 22423805, 22424317 / 20 / 21, 22438815, 22420817, Fax : (91-33) 22424325.
- **Chennai :** Tel.: (91-44) 25255200, (91-44) 25224557.

Branch Office :

- **Ahmedabad :** Tel.: (91-79) 26580428 / 0518 / 1856 / 1857 / 1861, Fax : (91-79) 26587783.
- **Nagpur :** Tel.: (91-712) 2526588, 2524125, 2526038, Fax : (91-712) 2541142.
- **Ranchi :** Tel.: (91-651) 2562069, 2562651, Fax : (91-651) 2562027.
- **Bangalore :** Tel.: (91-80) 22262062, Fax : (91-80) 22253472.
- **Hyderabad :** Tel.: (91-40) 23314025, 23316446, 23390544, Fax : (91-40) 23318557.
- **Kochi :** Tel.: (91-484) 2359661, 2359372, 2359190, Fax : (91-484) 2359589.

Representative Offices :

- **Surat :** Tel.: (91-261) 22683330, Mob.: 09825404016.
- **Indore :** Tel.: (91-731) 2421135, Mob.: 09826041910.
- **Lucknow :** Tel.: (91-522) 3954033, 2344962, Mob.: 09415086044.
- **Ludhiana :** Mob.: 09814640863.
- **Coimbatore :** Mob.: (91-422) 3220388.
- **Rourkela :** Mob.: 09437248230.

